

STANDARD ARCH SIZE 標準ア-チ		850 <sup>W</sup> x 600 <sup>H</sup> mm	
機 械 寸 法	OVERALL WIDTH 全 幅	1863 mm	
	OVERALL HEIGHT 全 高	1547 mm	
	TABLE HEIGHT テ-ブル高	432 mm	
	OVERALL DEPTH 奥 行	609 mm	
	MACHINE MASS 質 量	約300 kg	
PACKAGE SIZE 梱包可能寸法		MAX 最大	820 <sup>W</sup> x 580 <sup>H</sup> (mm)
		MIN 最小	80 <sup>W</sup> x 30 <sup>H</sup> (mm)
TENSION RATE 引 締 能 力		MAX 最大	784 N 150mm (ストロ-ク)
STRAPPING RATE 梱 包 能 力		1.8 SEC	
STRAP COIL 使 用 バンド		200 <sup>ID</sup> x 450 <sup>OD</sup> x 200 <sup>W</sup> (mm) (5,6), 9, 12, 15.5mm (1/4, 3/8, 1/2)	
POWER SUPPLY 動 力 源		PHASE 50/60Hz, 0.65kVA 1 100V, 110V, 220V, 230V, 240V (3 200V)	

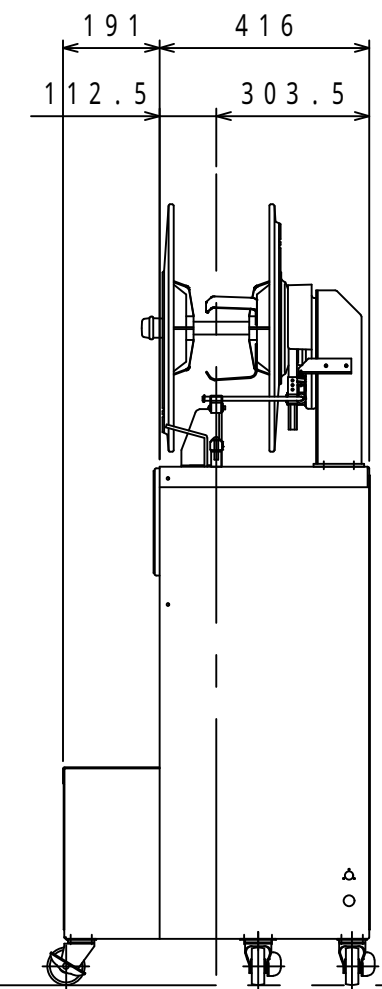
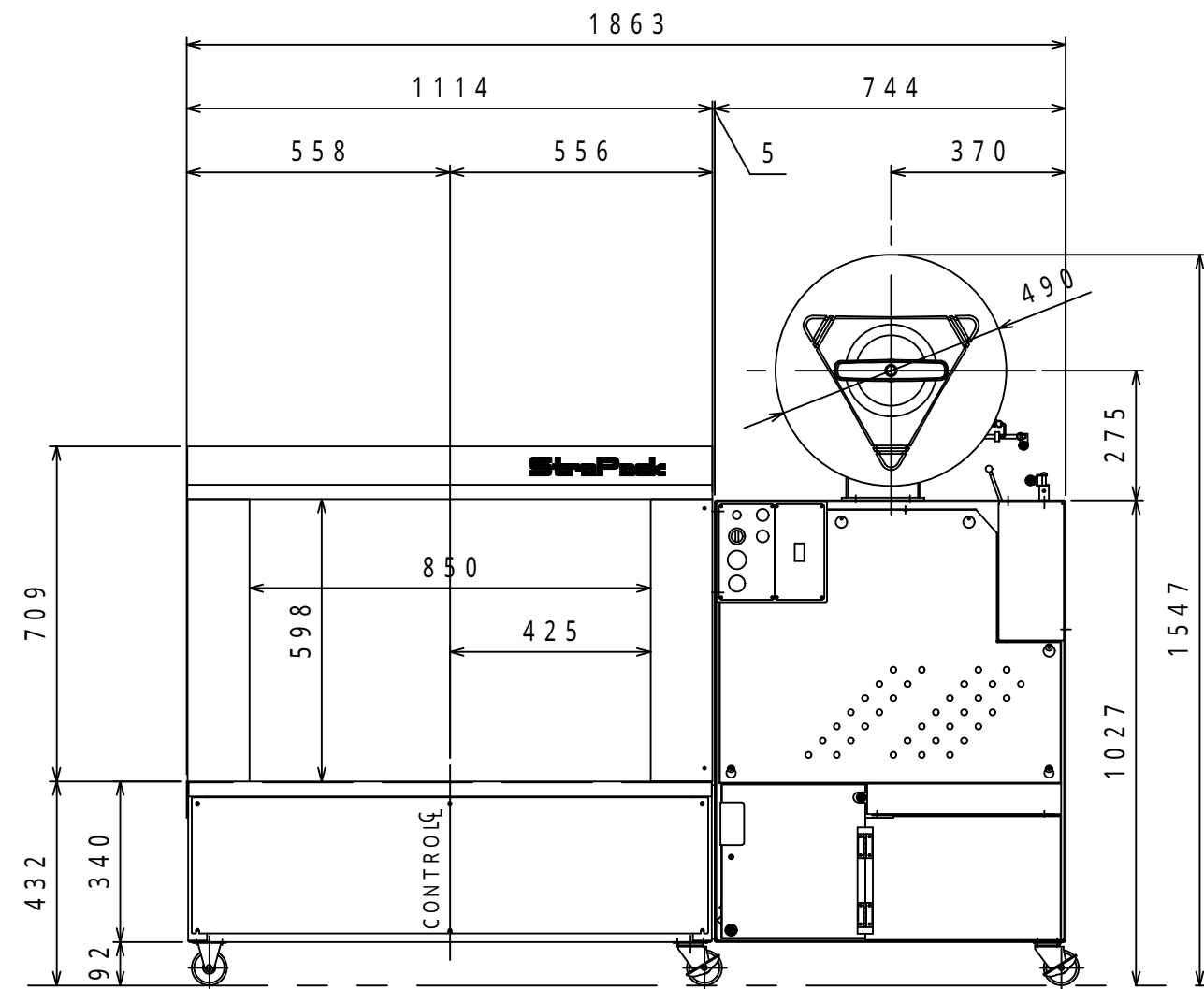
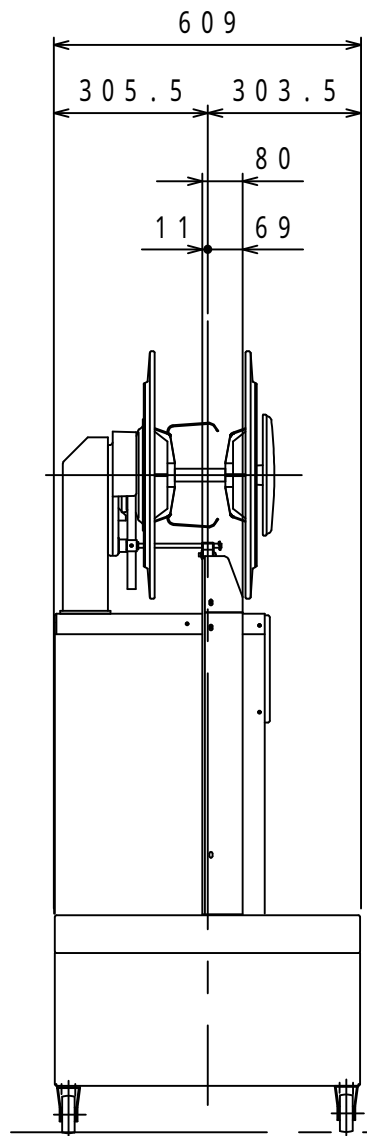

承認 APPROVED BY	検図 CHECKED BY	製図 DESIGNED BY	年月日 DATE
		小林	2004-09-03
第3角法 TRIGONOMETRY	名称 DESCRIPTION AUTOMATIC STRAPPING M/C		
尺度 SCALE 1 : 15	低床型全自動梱包機		
機種 MODEL RQ-8 LD	図番 DRAWING No. 905-0850601		

StrapPack