

manibo

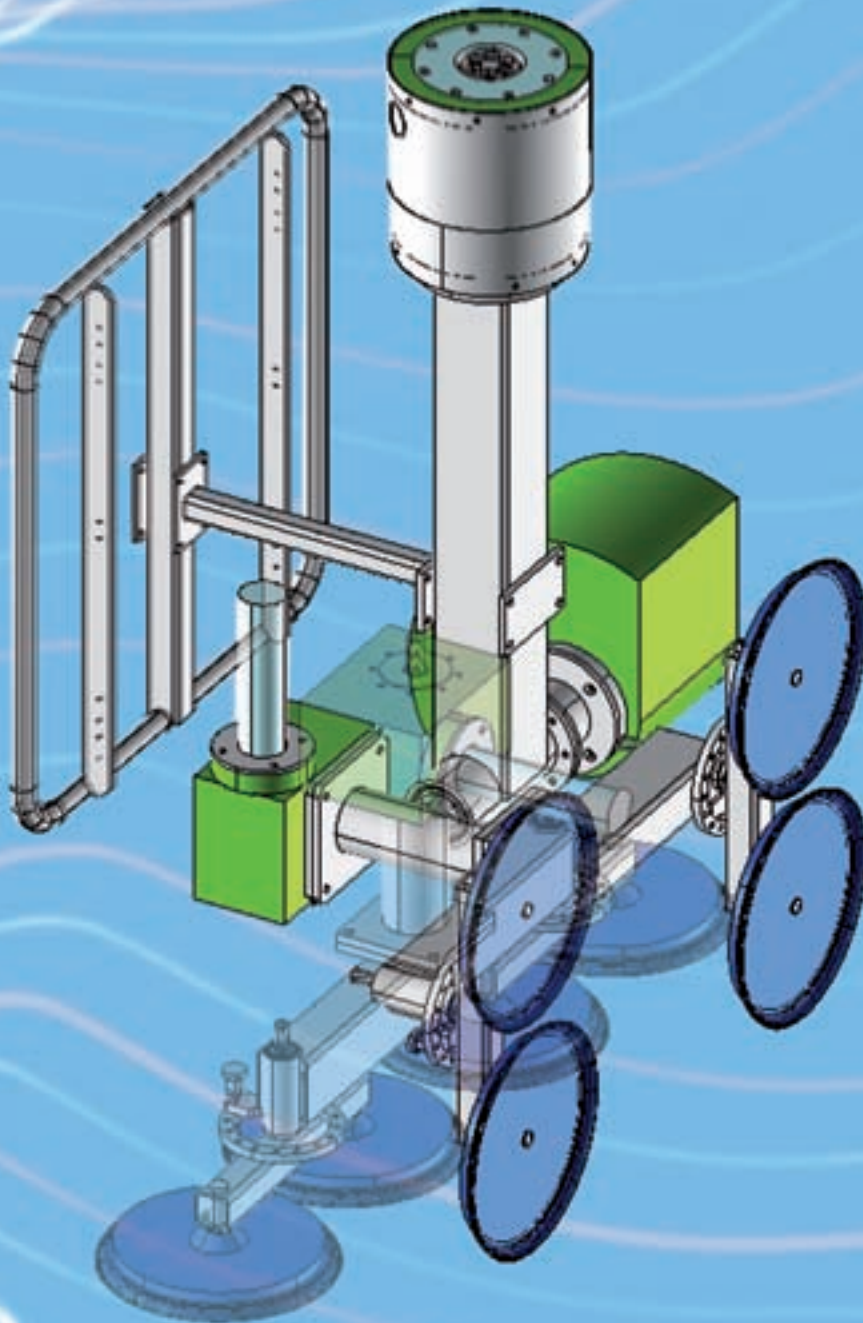

**Manipolatori
Industriali**





**Manipolatori
Industriali**

MANIBO s.r.l. ricopre una posizione consolidata nel campo della manipolazione industriale ed è ormai un partner di riferimento per numerose Aziende di primaria importanza non solo in Italia ma in tutto il mondo.

Le numerosissime applicazioni realizzate per soddisfare le specifiche richieste dei clienti per la soluzione dei loro problemi di movimentazione, ne alimentano ogni giorno la crescita e la presenza sul mercato.

Oltre a fornire manipolatori per applicazioni ed ambienti di lavoro consueti, MANIBO pone particolare cura nella soluzione di problemi di movimentazione in Aziende del settore alimentare, farmaceutico e per ambienti ATEX.

La struttura organizzativa MANIBO, in adeguamento alla necessità di operare sempre più rapidamente, garantisce tempestivamente risposte e consegne.

MANIBO s.r.l. occupies a very established position in the field of the industrial manipulation and by now is a reference partner for many leading Companies, not only in Italy but all over the world.

The large number of applications manufactured to satisfy the specific customers' requests, to solve their handling problems, increases every day the growing up and the presence on the market.

Besides to supply manipulators for application in usual working places, MANIBO pays particular care to solve handling problems in food and chemical industries, or in environments classified ATEX.

MANIBO's organization, following the necessity to operate always more quickly, can warrant answers and delivery always at the right time.



■ MANIPOLATORI PNEUMATICI A BRACCIO <i>PNEUMATIC ARM MANIPULATORS</i>	4
■ BILANCIATORI PNEUMATICI A FUNE <i>PNEUMATIC ROPE BLANCERS</i>	11
■ APPLICAZIONI PER INDUSTRIA ALIMENTARE <i>APPLICATIONS FOR FOOD INDUSTRIES</i>	17
■ ESECUZIONI PER AMBIENTI ATEX <i>EXECUTIONS FOR ATEX ENVIRONMENTS</i>	18
■ ACCESSORI <i>ACCESSORIES</i>	19
■ ATTREZZI DI PRESA MODULARI <i>MODULAR HANDLING ATTACHMENTS</i>	19



Con i **Manipolatori Industriali MANIBO** un singolo operatore può facilmente movimentare carichi di notevoli dimensioni e peso. MANIBO presenta una gamma di otto manipolatori a colonna standard con portate lorde che vanno dai 100 kg fino ai 1.000 kg e raggio di lavoro variabile dai 2 ai 4,3 m. Il manipolatore può essere fissato direttamente a pavimento oppure montato su base autostabile che ne permette l'utilizzo in differenti posizioni senza la necessità di alcun ancoraggio.



Tutti i modelli possono essere appesi a carrelli, motorizzati o a spinta, traslanti lungo vie di corsa aeree, per consentire l'ampliamento dell'area di lavoro.

In base alle esigenze del cliente MANIBO progetta e costruisce l'attrezzo di presa idoneo alla movimentazione dello specifico carico. Tale attrezzo viene collegato al braccio del manipolatore mediante giunto rotante, avente sette passaggi d'aria interni, in modo tale da poterlo orientare a piacimento senza alcun impedimento. L'attrezzo di presa può essere inoltre dotato di movimenti asserviti pneumaticamente al fine di ruotare, basculare o semplicemente inclinare il pezzo sollevato.

*Using **MANIBO Industrial Manipulators**, loads having big weight and dimensions can be handled by only one operator. MANIBO production range consists of eight standard manipulators, with gross capacities from 100 kg to 1000 kg and working radius from 2 to 4.3 m. Manipulators can be fixed directly to the ground or on a forkliftable self bearing base, to have the possibility to use the manipulator in different working places, without the necessity to foresee any fixing device.*

All the models can be hanged to powered or pushing trolleys, sliding on suspended rails, to have the possibility to enlarge the working zone.

MANIBO designs and manufactures, on customers' request, special handling attachments suitable to the specific handling problem. These handling attachments is connected to the manipulator arm by a rotating joint with seven internal air passages, so to rotate it continuously without problems. The handling attachment can also be connected to pneumatic devices, to tilt, to rotate or simply to bend the handled part.

MANIPOLATORI Manipulators



■ Serie BSP con portate fino a 100 kg
Model BSP with capacities up to 100 kg



■ Serie BLP con portate fino a 210 kg
Model BLP with capacities up to 210 kg



■ Serie MBL con portate fino a 1000 kg
Model MBL with capacities up to 1000 kg



■ Manipolatore con gancio
Manipulator with hook



TIPOLOGIE DI PRESA

Kind of Gripping



■ Magneti azionati pneumaticamente
Magnets pneumatically operated



■ Ventose
Vacuum pads



■ Mandrini per presa interna
Mandrels for gripping inside



■ Pinze pneumatiche
Pneumatic gripping tools



PINZE PER COMPONENTI MECCANICI

Gripping Tools for mechanical parts



■ Portiere auto
Car doors



■ Compressori
Compressors

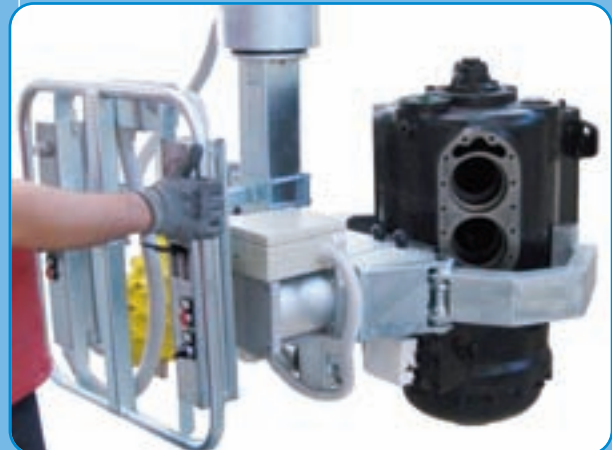

■ Motori elettrici
Electric motors



■ Ingranaggi
Gears



PINZE AUTOCENTRANTI

Self centering Gripping Tools



■ Casse metalliche
Metal boxes



■ Grosse scatole
Big parcels



■ Fusti
Barrels



■ Respingenti
Buffers



ATTREZZI DI PRESA PER VETRI, LAMIERE E PANNELLI

Handling attachments for Glasses, Metal Sheets and Panels



■ Con dispositivo di ribaltamento
With overturn device



■ Con inclinazione e rotazione pneumatica
With pneumatic bending and rotation

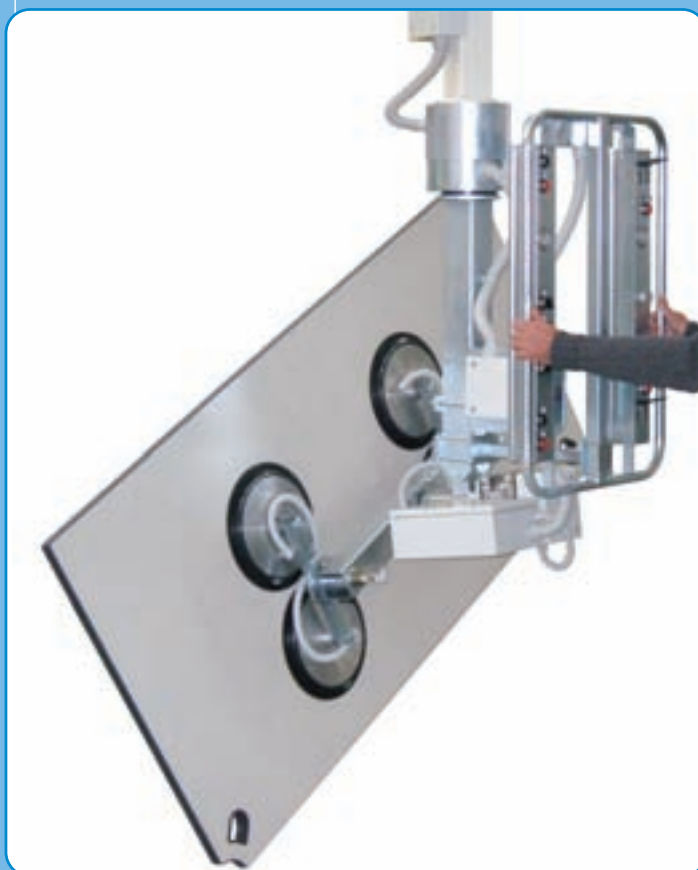

■ Con basculamento e rotazione pneumatica
With pneumatic tilting and rotating device



■ Con basculamento pneumatico
With pneumatic tilting device



ATTREZZI DI PRESA SPECIALI CON VENTOSE *Special Handling Attachments with Suction Cups*



■ Mini piscine
Mini pools



■ Articoli ceramici freschi
Fresh ceramic tiles



■ Armadi metallici con rotazione
Metal cases with rotation



■ Vasche da bagno
Baths



Bilanciatori pneumatici a fune MANIBO sono particolarmente adatti alla rapida movimentazione di carichi nelle linee di produzione. L'esecuzione standard a colonna prevede un braccio articolato di raggio 3 m all'interno del quale è alloggiato il dispositivo di bilanciamento, avente portata fino a 75 kg.



Sia la rotazione del braccio rispetto alla colonna che quella dell'articolazione è di 360° continua, grazie ai passaggi interni dell'aria. La colonna può essere fissata direttamente al pavimento oppure montata su base inforcabile autoportante per utilizzare il bilanciatore in differenti postazioni.

Il bilanciatore è completato dallo specifico attrezzo di presa costruito in funzione delle richieste del cliente.

Il bilanciatore MANIBO è realizzato anche in versione adatta ad essere appesa a carro ponte o gru a bandiera, eventualmente in sostituzione di un paranco elettrico già esistente.

MANIBO pneumatic rope balancer are particularly indicated for quick handling of loads in producing lines. The standard execution on column has an articulated arm 3 m long where, inside, is located the balancing device, with capacity of 75 kg. Both the rotation of the arm around the column, than the rotation of the second arm are of 360° continuous, thanks to a rotating joint with internal air passages. The column can be fixed directly to the ground or to a forkliftable self bearing base, to have the possibility to use the balancer in different working places.

Balancers are supplied with special handling attachments, designed and manufactured on specific customer's request.

MANIBO balancer are also supplied in version for jib cranes and bridge cranes, in case to replace an existing electric chain hoist.



ATTREZZI CON PRESA INTERNA

Tools with Internal Gripping



■ Bobine
Bobbins



■ Rotoli
Rolls



■ Componenti meccanici
Mechanical parts



■ Fusti di birra
Beer barrels



ATTREZZI CON PRESA ESTERNA

Tools Gripping from Outside



■ Teste motore
Engine heads



■ Motori elettrici
Electric motors



■ Sedili
Seats



■ Top lavatrici
Washing machines tops



ATTREZZI DI PRESA MECCANICI

Mechanical Handling Attachments



■ **Cassette**
Boxes



■ **Per presa e ribaltamento cassette**
For gripping and overturning of cases



■ **Fustini**
Barrels



■ **Sacchi**
Sacks



ATTREZZI DI PRESA A VENTOSA

Handling Attachments with Suction Cups



■ Esecuzione standard
Standard execution



■ Con ventose laterali
With pads at the side



■ Scatole in cartone
Carboard boxes



■ Sacchi
Sacks



ATTREZZI DI PRESA CON MAGNETI

Handling Attachments with Magnets



■ Magnete azionato pneumaticamente
Magnet pneumatically operated



■ Attrezzi magnetici speciali
Special magnetic handling attachments



■ Attrezzo di presa a due magneti
Handling attachment with two magnets



MANIBO è in grado di fornire manipolatori pratici e veloci anche per **ambienti alimentari e farmaceutici**, per la movimentazione di scatole, sacchi, pannelli, lastre e forme di formaggio.

■ Stampi per prosciutti
Moulds for hams



MANIBO can supply practical and quick use manipulators also for **food and pharmaceutical industries**, for handling of boxes, sacks, panels, sheets and whole cheeses.

■ Salumi
Salami



■ Manipolatori realizzati in acciaio inox
Manipulator manufactured in stainless steel



■ Formaggio
Cheese





MANIBO fornisce Manipolatori e Bilanciatori per ambienti classificati **ATEX**.

MANIBO supplies Manipulators and Balancers classified for **ATEX** environments.

manibo s.r.l. **CE**
MANIPOLATORI INDUSTRIALI BOLOGNA
Calderara di Reno BO - ITALIA

MODELLO: **BFCS 75**
ANNO DI COSTRUZIONE: **2009**
IN° DI MATRICOLA: **M0948**

Ex II 2G c ITA T2

■ Bilanciatore a fune per fustini
Rope balancer for drums



■ Bilanciatore a fune per sacchi
Rope balancer for sacks



■ **Basi Inforcabili autoportanti e vie di corsa**
Forkliftable self bearing bases and rails



Vie di corsa per traslazione, manipolatori a braccio e bilanciatori a fune, complete di strutture di sostegno. La traslazione può essere a spinta o motorizzata, con comandi sull'impugnatura del manipolatore.

Rails for sliding of arm manipulators or rope balancers, with supporting frames. The translation can be manual pushing or powered, with controls located on the handle of the manipulator.

Grazie alla composizione modulare degli attrezzi di presa, sia per i manipolatori a braccio che per i bilanciatori a fune, il cliente ha la possibilità di sostituirli successivamente o di modificarne i movimenti, qualora cambiassero le esigenze produttive o le tipologie degli oggetti da movimentare.

Thanks to the modular composition of the handling attachments, both for the arm manipulators than for the rope balancers, the customer has the possibility to change the applications or to modify the movements, in case that the production necessities and the kind of the parts to handle should change.

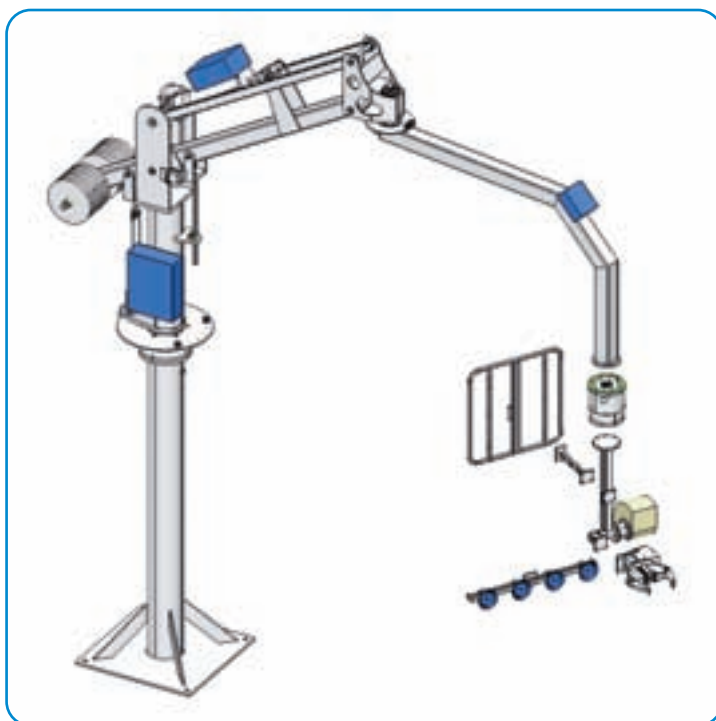



Sede legale / Registered office

Via Paolo Costa, 16
40137 Bologna

Stabilimento / Workshop

Via Armaroli, 16 a/b
40012 Calderara di Reno (Bo)
Tel. +39 051/64.68.143
Fax +39 051/64.68.179
E-mail: manibo@mani-bo.com
Web: www.mani-bo.com